

## 35 WATER AND ICE

Construction over and around water and ice presents special dangers. Precautions specifically developed for such construction must be taken before work begins.

This chapter outlines general safeguards that must be followed whenever personnel are required to work over water or on ice, including construction on bridges, wharves, dams, locks, and breakwaters.

### Guardrails

The requirements for guardrails specified in this manual and in Section 26 of the Construction Regulation apply to work stations over water or ice.

### Ramps

Ramps must be

- at least 46 centimetres (18 inches) wide
- not sloped more than 1 in 3 (20 degrees) and
- where slope exceeds 1 in 8 (6 degrees), have cleats 19 x 38 millimetres (1 inch by 2 inches) secured at regular intervals not more than 50 centimetres (20 inches) apart.

When a ramp is used for equipment such as wheelbarrows and a worker may fall from the ramp a distance of 1.2 metres (4 feet) or more — or may fall any distance into water — the ramp must be provided with guardrails (Figure 122).

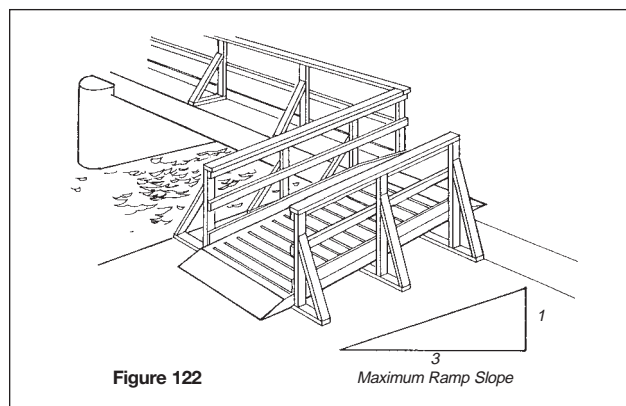

### Floating Work Platforms

When used on a construction project, rafts, scows, and similar vessels are considered work platforms. As such, they are subject to certain requirements.

- Guardrails must be provided along open edges. The guardrails may be removed at the working side of the platform, provided workers are protected by alternate measures of fall protection.
- Workers on floating platforms must wear lifejackets. A lifejacket provides enough buoyancy to keep the

wearer's head above water, face up, without effort by the wearer.

- Appropriate rescue measures must be prepared.

In addition, the positioning and securing of vessels used as work platforms should be supervised and undertaken by experienced personnel.

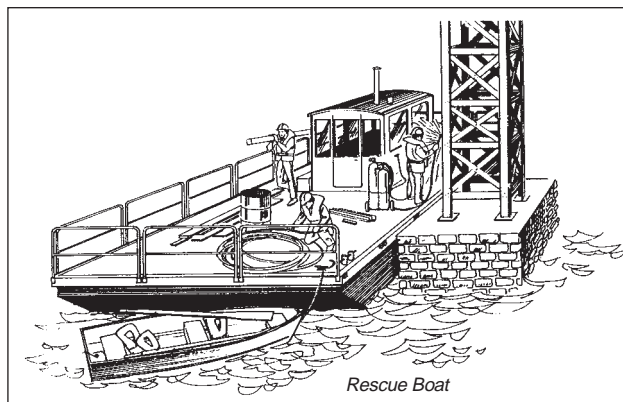

### Fall-Arrest Systems

The requirements specified in the chapters on Guardrails and Personal Fall Protection in this manual apply to work over water or ice.

### Safety Nets

Safety nets may be necessary when structural design, loading access, worker mobility, or other factors make guardrails and fall-arrest systems impractical (Figure 123).

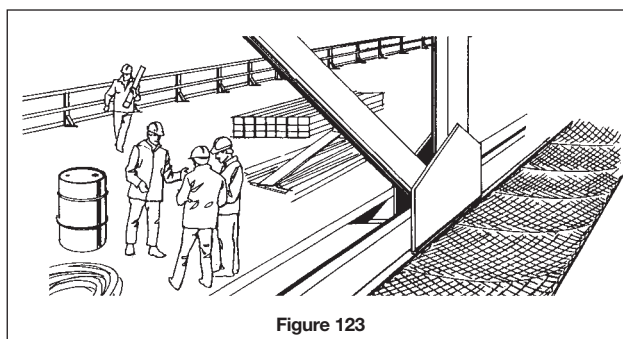

Safety nets must be

- designed, tested, and installed in accordance with ANSI Standard 10.11-1989, *Personnel and Debris Nets for Construction and Demolition Operations*
- installed by a competent worker
- inspected and tested by a professional engineer or competent person under the engineer's supervision before the net is put into service.

The engineer must document the inspection and testing of the safety net and sign and seal the document. A copy of the document must be kept at the project while the safety net is in service.

## Lifejackets and PFDs

A PFD is a personal flotation device.

A **lifejacket** is a PFD that provides buoyancy adequate to keep the wearer's head above water, face up, without effort by the wearer.

Other PFDs do not provide this protection. Some provide flotation only.

**Lifejackets** must be worn by workers exposed to the danger of drowning in water deep enough for the lifejacket to be effective. Workers must use an approved lifejacket when travelling on water or while at a project over or adjacent to water.

For boating to and from the worksite, boats must be equipped with one approved lifejacket for each person on board.

“Approved” refers to approval by Transport Canada (look for the Transport Canada label).

## Rescue

Where personnel are exposed to the risk of drowning, at least two workers **trained to perform** rescue operations must be available for a rescue operation. A seaworthy boat must also be available and furnished with the following rescue equipment (minimum):

- a ring buoy attached to 15 metres (50 feet) of polypropylene rope 9.5 millimetres (3/8 inch) in diameter
- a boat hook
- lifejackets for each person in the rescue crew.

Where a manually-operated boat is not suitable or where the water is likely to be rough or swift, the rescue boat must be power-driven. The engine should be started and checked daily.

Rescue equipment such as boats must be stored on or near the project, ready for use.

Where there is a current in the water, a single length of line must be extended across the water downstream from all work locations and be fitted with buoys or similar floating objects that are capable of providing support for a person in the water. The line must be securely fastened at each end to adequate anchorage.

An alarm system must be installed and maintained to alert workers to the need for an emergency rescue.

All of these requirements are illustrated in Figure 125.

## Transporting Workers by Boat

When navigating any Canadian waterway, boats and other floating vessels must comply with the requirements of the *Canada Shipping Act*. Refer specifically to the *Small Vessel Regulations* (Section 16.02) and *Collision Regulations* under the Act.

Commonly, boats used for construction operations are not longer than 6 metres (19'8"). Boats in this class must be equipped with at least

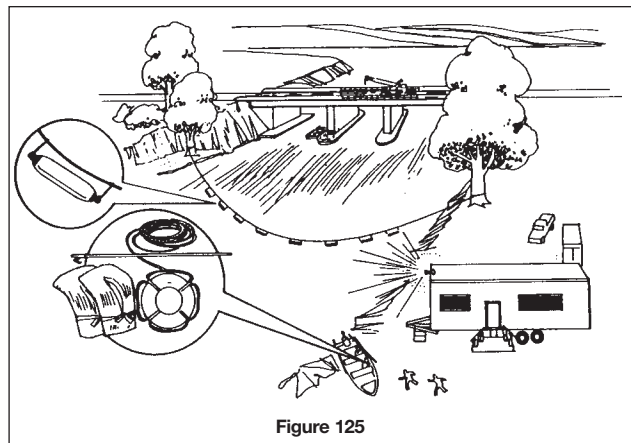

Figure 125

- one approved lifejacket for each person on board
- one paddle or an anchor with at least 15m of cable, rope, or chain
- one bailer or one manual pump
- one Class 5BC fire extinguisher if the craft has an in-board engine, fixed fuel tank, or fuel-burning appliance
- one sound signalling device.

All powerboats require some navigation lights if operated after sunset or before sunrise. For appropriate regulations, consult the *Safe Boating Guide* published by the Canadian Coast Guard, or the *Canada Shipping Act – Small Vessel Regulations* and applicable standards set out in the *Collision Regulations* under the Act.

## Ice Testing

Work, travel, and parking on frozen bodies of water should be avoided whenever possible and be done only as a last resort. The ice **must** be tested before any workers or vehicles are allowed onto the surface. Loads that may safely travel on ice may not necessarily be left on ice for extended periods of time. This applies especially to parked vehicles.

Before testing, learn as much as possible about ice conditions from local residents. Testing requires at least two persons on foot proceeding with caution. Each person must wear an approved lifejacket or, preferably, an approved floatable survival suit that protects against hypothermia.

For ice testing, a survival suit or lifejacket is required because a person falling into frigid water may lose consciousness and the suit or lifejacket will keep the person's face out of the water.

Members of the ice-testing crew should stay about 10 metres (30 feet) apart. The lead member must wear a safety harness attached to a polypropylene rescue rope 9.5 millimetres (3/8 inch) thick, at least 20 metres (65 feet) long, and held by the trailing crew member (Figure 127).

Clear blue ice is the most desirable for strength. White or opaque ice forms from wet snow and has a higher air content. It is less dense and therefore weaker than clear blue ice. Grey ice indicates the presence of water from thawing and should not be trusted as a load-bearing surface.

The lead crew member should cut test holes every 8 metres (25 feet) or so. If ice is less than 10 centimetres (4 inches) thick, the lead and trailing crew members should vacate the area immediately.

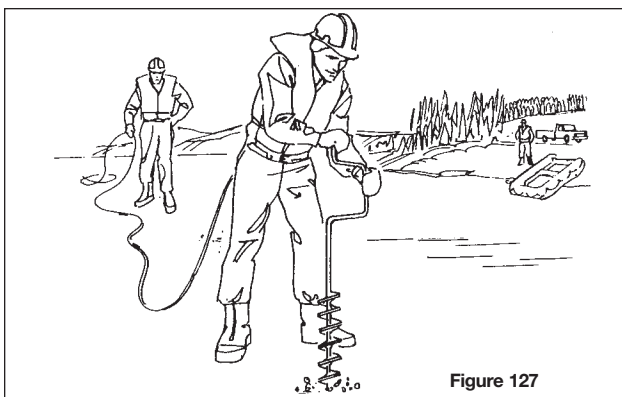

Figure 127

The biggest uncertainty about the load-bearing capacity of ice is the natural variation in thickness and quality that can occur over a given area. Currents and springs can cause variations in thickness without changing the overall surface appearance of the ice. Considerable variation in ice thickness can occur where rivers have significant currents or high banks. Similar situations occur in lakes at the inlet and outlet of rivers.

Only the thickness of continuously frozen ice should be used to determine bearing capacity. The basis for capacity should be the **minimum** thickness measured.

In addition to testing for thickness, crews should check ice for cracking.

Ice thickness (Figure 128) is determined by the full thickness of clear blue ice plus half the thickness of any white, continuously frozen ice (source: *Safety Guide for Operations Over Ice*, Treasury Board of Canada).

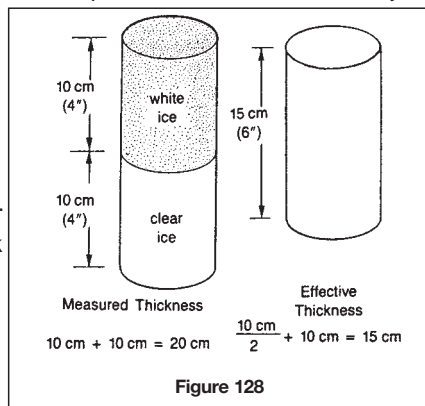

Figure 128

For repeated work or travel over ice, the surface must be tested regularly to ensure continued safety. Ice must also be tested regularly near currents or eddies and around permanent structures like abutments.

### Bearing Capacity of Ice

Where heavy equipment such as cranes or structures such as concrete forms are to be placed on ice for extended periods, ask an experienced consultant for advice on bearing capacity, load methods, and inspection procedures. With professional advice it is possible to increase bearing capacity considerably. But careful control is required over surface operations, loading procedures, and ice monitoring.

In other cases, refer to Graph 1 for allowable **moving** loads on various thicknesses of clear blue ice. Remember: the graph is **not** to be used for loads parked, stored, or otherwise left stationary for long periods of time.

Certain types of cracking can affect the bearing capacity of ice. For a single dry crack wider than 2.5 centimetres (1 inch), reduce loads by one third; for intersecting cracks of this size, reduce loads by two thirds. Dry cracks can be repaired by filling in with water or slush.

A wet crack indicates penetration through the ice to water below. Bearing capacity can be dangerously lowered. For a single wet crack, reduce loads by three quarters. Most wet cracks refreeze as strong as the original ice. A core sample should be taken to determine the depth of healing.

### Other Considerations

- Ice roads must be at least 40 centimetres (16 inches) thick along their entire length and should be clearly marked.
- Ice roads should not be built up more than 10 centimetres (4 inches) in one day and must not be used or reflooded until the top layer has completely frozen.
- While an ice road is in use it must be checked daily for thickness, cracks, thawing, and other conditions.
- All rescue equipment listed earlier in this chapter must be readily available.
- A life ring attached to 20 metres (65 feet) of polypropylene rescue rope 9.5 millimetres (3/8 inch) thick must be kept within 35 metres (115 feet) of the work area.
- A warm place such as a truck cab or hut must be provided and made known to personnel near the worksite.

For more information on the bearing capacity of ice, see *Safety Guide for Operations Over Ice*, by the Treasury Board of Canada.

### Recommended Bearing Capacity Based on Experience — Moving Loads Only

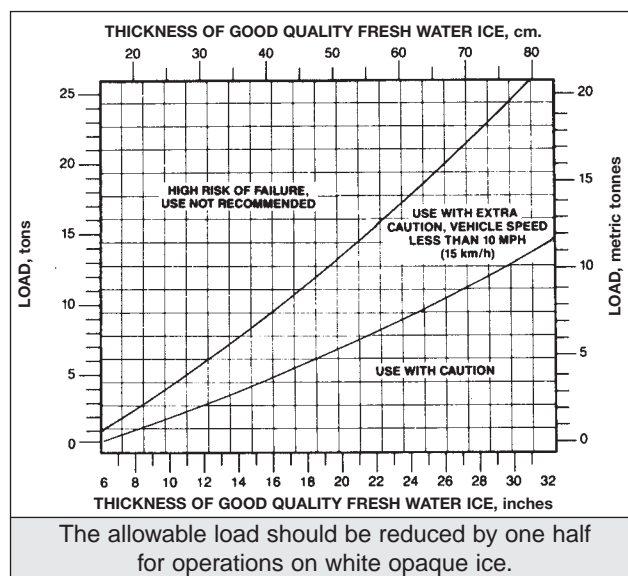

The allowable load should be reduced by one half for operations on white opaque ice.

Graph 1 Courtesy Treasury Board of Canada

### Ice thickness versus ice strength

This table provides the safe load for a given ice thickness of

- fresh ice (lake and river ice) and
- sea ice (St. Lawrence River, Gulf of St. Lawrence, etc.)

SAFE LOAD	OPERATION	FRESH ICE	SEA ICE
One person	at rest	8 cm	13 cm
0.4 ton	moving slowly	10 cm	18 cm
10 ton tracked vehicle	moving slowly	43 cm	66 cm
13 ton aircraft	parked	61 cm	102 cm

Table provided by the National Research Council of Canada.