

## 8 BACK CARE

Nearly 25% of the lost-time injuries in construction are related to the back. More than half of these injuries result from lifting excessive weight or lifting incorrectly.

To prevent injuries, you need

1. proper posture
2. correct lifting techniques
3. regular exercise.

### Posture

Correct posture is not an erect, military pose. It means maintaining the naturally occurring curves in your spine.

You have two inward curves – at the neck and low back – and one outward curve at the upper back.

Keeping your spine aligned in this manner reduces everyday stresses on your back and minimizes the effects of the normal aging process on the spine.

When working in a crouched, bent, or stooping position for a prolonged period, take regular breaks by standing up and bending backwards three times.

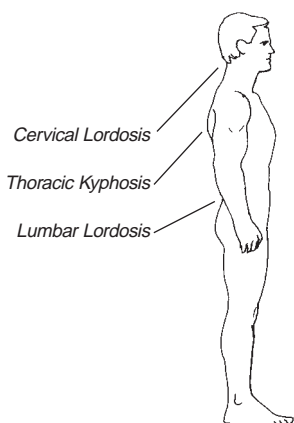

**Correct Posture**

You have two inward curves (lordosis), one each at the neck and low back, and one outward curve (kyphosis) at the upper back.

### Common Posture

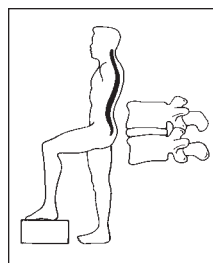

**Normal**

Prolonged standing often causes an increased curve in your back. Elevating one foot on a stool or any other object (a phone book or brick will do) will take stress off the lower spine.

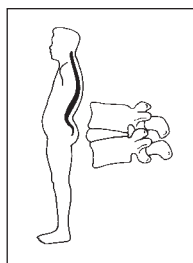

**Sway Back**

An increased curve in your lower back will jam the vertebrae together (sway back). If held too long, the position will cause lower back muscles and ligaments to tighten and lead to lower back pain.

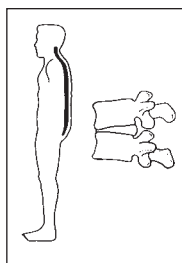

**Flat Back**

Too little curve (flat back) will put extra pressure on the front of your discs. This may contribute to disc problems and pain.

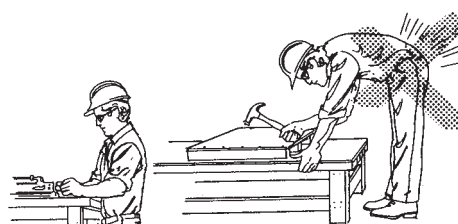

For bench work, the right height is vital.



Precision work

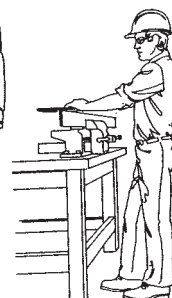

Light work



Heavy work



### Work Overhead

When working overhead in an arched position for prolonged periods, take regular breaks by returning to stable footing and bending forward three times.

If possible avoid working on ladders. Use scaffolds instead, especially for long-term tasks or for jobs where you must handle heavy materials.

### Materials Handling

#### Proper Lifting

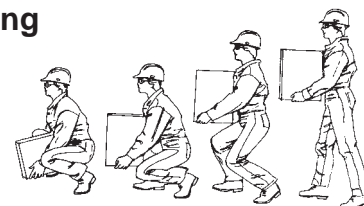

1. Plan your move.
  - Size up the load and make sure pathway is clear.
  - Get help as needed.
  - Use a dolly or other device if necessary.
2. Use a wide-balanced stance with one foot slightly ahead of the other.
3. Get as close to the load as possible.
4. Tighten your stomach muscles as the lift begins.
5. When lifting, keep your lower back in its normal arched position and use your legs to lift.
6. Pick up your feet and pivot to turn – don't twist your back.
7. Lower the load slowly, maintaining the curve in your lower back.

Your back can manage most lifts – if you lift correctly.

Avoid lifting above shoulder height. This causes the back to arch, placing heavy stress on the small joints of the spine.

Do not catch falling objects. Your muscles may not have time to coordinate properly to protect the spine.

**Push rather than pull.** Pushing allows you to maintain the normal curves in your back.

### Weight Transfer

Pull the object toward you while transferring your weight to the lift side.

Lift only to the level required.

Shift your weight to your other leg while pushing the object into position.

### Sheet Materials

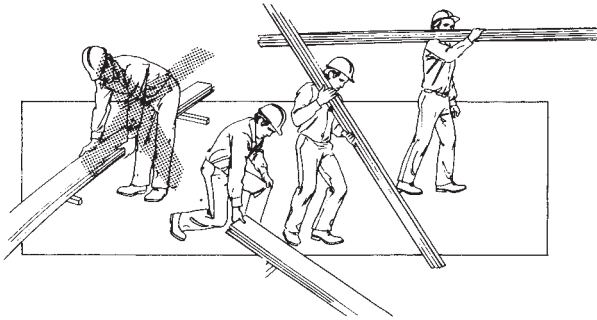

*If sheets are on the floor, use the same technique as for lifting long lumber. Lift one end first.*

When you handle sheet materials, use proper techniques to protect your back. Where possible, store sheets at a convenient height and above ground on timbers or trestles.

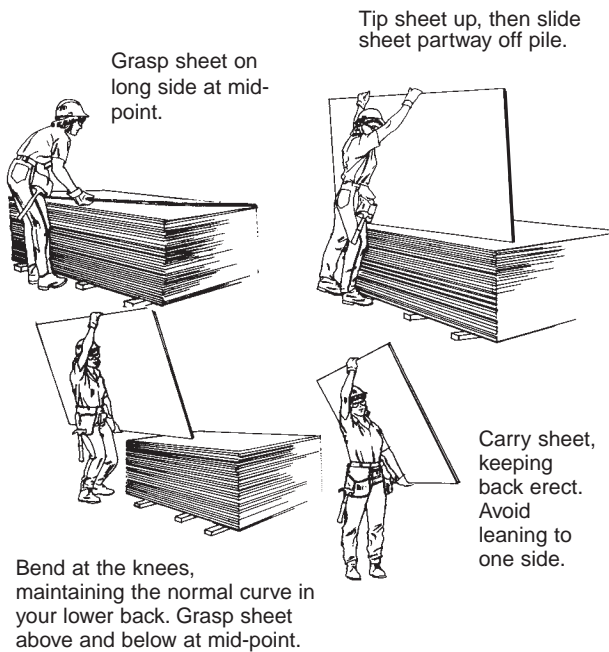

*For long carries, use carrying handles. Better yet, if surface is smooth and hard use a drywall cart.*

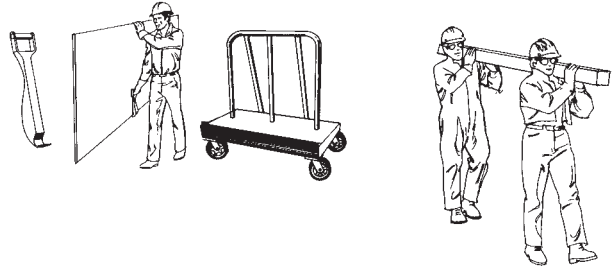

### Two-Person Lift

Lifters should be of similar height. Before starting they should decide on lifting strategy and who will take charge.

For a two-person lift of a long load, the lifter who takes charge must see that the load is carried on the same side, with a clear line of vision. Begin by lifting load from ground to waist height. Then lift the load from waist to shoulder.

### Carrying on Stairs

Use your stomach muscles to help support and protect your back. If possible, the tallest and/or strongest person should be at the bottom of the load.

### Balance

Avoid one-handed carrying if possible. Try to distribute the weight evenly on each side. If you can't avoid one-handed carrying, such as with a single pail, hold the free arm either straight out or on your hip as a counterbalance.



### Mechanical Help

Use a cart or dolly for transporting tools and equipment wherever possible.

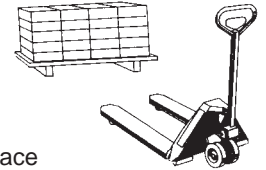

Consider using pallets where surface conditions allow.

Rolling frame scaffolds with a few tube-and-clamp components may be useful for moving heavy objects such as motors or drives where other devices such as forklifts are not available.

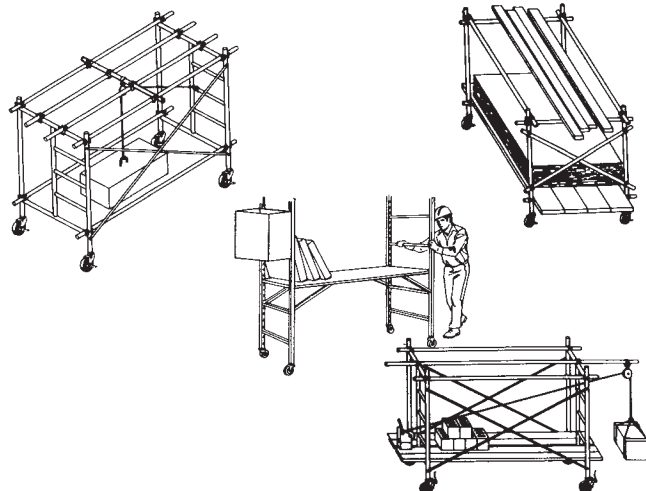



Wheelbarrows with dual wheels are a great improvement over single wheels. Better balance and increased flotation over soft ground make wheeling easier on the back.

Lift tables with casters for heavy components can be helpful. These tables are light, carry loads of

several hundred pounds, and have adjustable heights from one to several feet.

**Exercise**

Construction work strengthens some muscles while others become shorter and weaker, creating a muscle imbalance. A regular exercise program can help to prevent this from happening.

A good exercise program should consist of four basic parts:

1. warm-up
2. main workout
3. strength and stretch
4. cool-down.

**Warm-Up**

This is a general exercise program only. Before starting any exercise program, consult your doctor first.

If you have any concerns or experience any pain while doing the exercises, stop and consult your doctor.

**1. March in Place**

Start: Stand in position.

Action: Pump arms and legs in opposite directions. Make sure heels contact ground. Continue 3 to 5 minutes.



**2. Arm Circles**

Start: Stand with arms raised horizontally and slightly in front of shoulders, palms down, and feet shoulder-width apart.

Action: Rotate arms in forward circular motion for 15-30 seconds. Relax. Repeat 3-5 times.

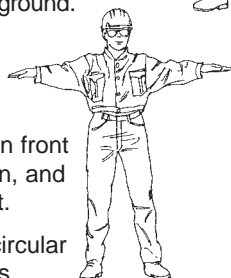

**Stretching Program**

The following stretching exercises are of greatest value before work starts. They may, however, be done at any convenient time. Whenever they are done, a brief warm-up (walking briskly or jogging on the spot) is most beneficial.

The exercises should be performed in a slow, controlled manner and held in a sustained stretch. Avoid bouncy, jerky movements which may tear muscle fibres.

**3. Knees to Chest**

Start: Support yourself securely with one hand.

Action: Pull your knee toward your chest and grasp around your knee with your free hand. Hold the stretch for 30 seconds. Lower your leg to the ground and repeat with the other leg. Repeat three times for each leg.



**4. Hip Stretch**

Start: Stand with one foot in front of the other. Place hands above the knee of the front leg.

Action: Gently bend front knee, keeping back foot flat on the floor. Hold 20-30 seconds. Repeat with other leg. Repeat three times for each leg.

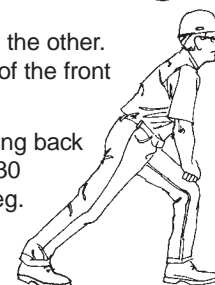

**5. Thigh Stretch**

Start: Support yourself with one hand on something secure.

Action: Bend your leg back and grasp your ankle with your free hand. Gently pull your ankle toward your body, keeping your trunk straight. Hold 20 to 30 seconds; repeat with other leg. Repeat three times for each leg.

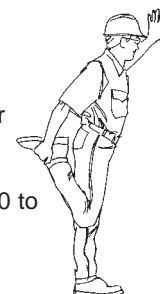

**6. Calf Stretch**

Start: Stand slightly away from a solid support and lean on it with your outstretched hands. Bend the forward leg and place the other leg straight behind you.

Action: Slowly move your hips forward, keeping the heel of the back leg on the ground. Hold 30 seconds, relax, and repeat with other leg. Repeat three times for each leg.

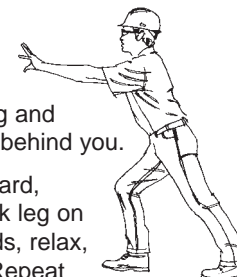

**7. Hamstring Stretch**

Start: Place the back of your heel on a platform at a comfortable height. Bend your supporting leg slightly.

Action: Looking straight ahead, slowly bend forward at the hips until you feel a good stretch at the back of the raised leg. Hold 30 seconds and repeat with other leg. Repeat three times for each leg.

