

### List propane uses and locations on site

---



---



---



---



---

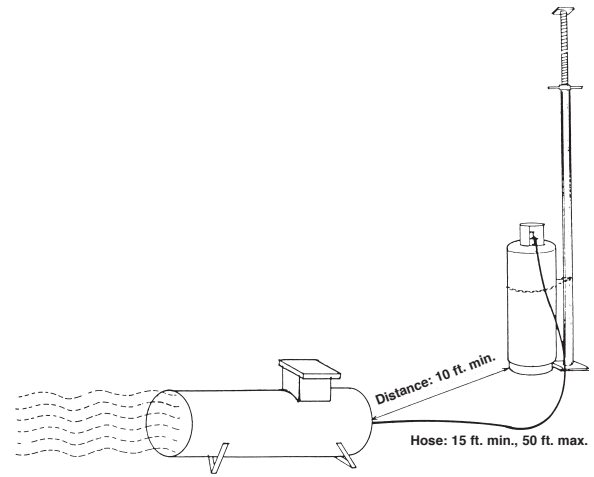

Secure the cylinder and keep it at least 10 feet away from a heater.

### Explain dangers

Explosion and asphyxiation are the main risks with propane. Asphyxiation means loss of consciousness and suffocation.

Propane gas by itself is odourless. But suppliers add a strong-smelling chemical to the gas so that you can smell leaks. The smell is like rotten cabbage.

Propane gas is heavier than air. If it leaks from equipment or cylinders, it can accumulate in low-lying areas such as basements, pits, and trenches.

If enough propane gas collects in a low-lying area, it displaces air. If you enter that area you may be overcome and lose consciousness.

Propane will explode if ignited. Simply turning on a light switch or an electric drill can ignite propane concentrations in a basement or trench.

Propane-fired equipment releases carbon monoxide (CO). Even in small doses, CO can kill you. It's a clear, colourless gas that you can't smell or taste. The first signs of CO poisoning are headache and fatigue. See the Safety Talk on carbon monoxide for more information.

### Identify controls

If propane equipment such as a torch or heater goes out in a confined or low-lying space, act quickly.

- Shut off the gas and leave the area.

- Don't go back to re-light the equipment.
- Don't enter the area. Inform your supervisor.

The best way to prevent leaks is to handle propane cylinders and equipment properly. [See Safety Talk on "Compressed gas cylinders" for how to deal with cylinders.]

- Whether you're transporting, using, or storing cylinders, make sure the relief valve is in contact with the vapour space in the cylinder.
- Keep propane cylinders at least 10 feet away from the heaters they are connected to.
- Don't let propane saturate your clothing. It may not feel or smell unusual, but clothing remains highly flammable for some time after exposure. Saturated clothing should be aired outside.
- Never expose any part of your skin to liquid propane. Propane under pressure is extremely cold and can cause frostbite or cryo-burns.

### Demonstrate

Review arrangements for storing, handling, and using propane on site.